

- 9.9.1 All components and specifications of dosed systems shall be submitted for approval to the Department or its authorized agent in accordance with the Department's Guidelines for Submittal of Onsite Wastewater System Applications.
- 9.9.2 Serial distribution systems shall not be approved for dosing situations.
- 9.8.3. Where a pump or dosing siphon is used to dose an onsite wastewater system; it shall have a capacity sufficient to deliver the required dose volume. Pump controls shall operate automatically and be sufficiently adjustable to deliver the required dose volume.
- 9.9.3 Only effluent quality pumps shall be utilized in dosing applications. Dewatering and grinder pumps are not approved for septic applications.
- 9.9.4 Effluent shall be dosed to the absorption area at a rate not greater than twenty-five (25) percent of the estimated daily usage outlined in Appendix B of this regulation.
- 9.9.5 A visible and audible high water alarm shall be required for all electrical dosing situations.
- 9.9.6 Stand-alone dosing tanks shall have a capacity sufficient to contain the required dose, storage for ballast not less than one quarter of the dose tank capacity, and emergency storage above the high water alarm not less than one third of the estimated daily usage.
- 9.9.7 The compartment of combination tanks used for dosing shall have a capacity sufficient to contain the required volume and must be hydraulically isolated from the primary compartment.
- 9.9.8 Pre-cast dosing tanks shall meet the same construction requirements for pre-cast septic tanks outlined in Section 11.6 of this regulation.
- 9.9.9 The approval of any distribution device utilized in dosing situations shall be at the sole discretion of the Department or its authorized agent.
- 9.9.10 Dosing from a Septic Tank
- 9.9.10.1 When dosing from the septic tank, the tank capacity shall be increased by not less than two hundred fifty (250 gallons) above that specified in Appendix C of this regulation.
- 9.9.10.2 A filtered pump vault approved by the Department for use in septic tanks shall be incorporated into all systems designed to be dosed from a septic tank.
- 9.9.10.3 The filtered pump vault shall be securely mounted to the tank in a manner that prevents movement of the vault during operation.
- 9.9.10.4 The minimum horizontal separation between the inlet baffle of the septic tank and the filtered pump vault shall be 3 feet.

9.9.10.5 When a system is dosed from a septic tank, the drawdown per dose cycle shall not be greater than 3 inches.

9.9.11 Electrical Connections (See Appendix H, figure 11.)

9.9.11.1 All electrical connections shall be complete at the time of final system inspection unless otherwise specified by the Department's authorized agent.

9.9.11.2 All system wiring shall be encased in electrical conduit.

9.9.11.3 All splices within system wiring shall be made with heat shrink connectors or waterproof wire nuts.

9.9.11.4 All electrical connections shall be made inside watertight splice boxes.

9.9.11.5 All conduit and connection boxes shall be sealed with electrical grease or other waterproof electrical sealant in order to minimize corrosion due to moisture and/or gasses escaping the system.

9.9.11.6 All system wiring shall comply with the Arkansas State Electrical Code.

9.9.11.7 Pumps and pump alarms shall not be on the same circuit.

9.10 Low Pressure Distribution (LPD)

Low pressure distribution allows an absorption area or secondary treatment filter to be dosed evenly across the entire area. The discharge assembly of LPD systems consists of small diameter piping with orifices drilled at predetermined intervals through which effluent is dosed to the absorption area or secondary treatment filter. All LPD systems shall meet the following requirements. (See Appendix H, figure 10.)

9.10.1 All piping in LPD systems shall be constructed of schedule 40 PVC pipe. All joints or connections shall be primed and welded with the appropriate chemical agents.

9.10.2 Orifices may range in size from 0.125 (1/8) inch to 0.1875 (3/16) inch. All orifices shall be centered in the pipe, pointed up, and shielded. In situations where the discharge assembly is located at a lower elevation than the pump, 25% of the orifice should be turned down to allow the system to drain between doses. For soils with high hydraulic conductivity, the orifice spacing shall not exceed 24 inches. For soils with moderate hydraulic conductivity, the orifice spacing shall not exceed 48 inches. Orifices shall not be installed within twelve inches of the manifold pipe.

9.10.3 In situations where the discharge assembly is located at a lower elevation than the pump, a 0.25 (1/4) inch siphon-breaker hole shall be drilled in the pump effluent line above the high water level to prevent siphoning. An extra 2 gallons per minute shall be added to the system flow rate to accommodate the siphon-breaker hole.

9.10.4 The orifice head (height of squirt) shall not be less than 5 feet.

9.10.5 The dose volume shall not exceed 0.5 gallons per orifice.

9.10.6 Plastic or brass valves, either globe or gate, shall be installed between the manifold and distribution laterals in order to facilitate orifice head adjustment. Valves may not be required on secondary treatment filters. All valves shall be encased in readily accessible valve boxes or similar encasement.

9.10.7 A 90-degree electrical sweep with threaded cleanout or valve shall be installed at each end of the laterals for maintenance. All cleanouts shall be encased in readily accessible valve boxes or similar encasement.

9.10.8 LPD absorption trenches shall contain a minimum of 8 inches of gravel and 4 inches of cover above the gravel bed. Approved gravel substitutes may be used in LPD design. (See Appendix H, figure 3.)

9.11 Construction Considerations

9.11.1 Careful construction is important in constructing a satisfactory absorption area. Attention should be given to the protection of the natural absorption properties of the soil. Care must be taken to prevent sealing of the surface on the bottom and sides of the trench. Trenches should not be excavated when the soil is wet enough to smear or compact easily. When significant smearing of the sidewalls or bottom of the absorption trench occurs during installation, construction shall be halted and the local Authorized Agent shall be contacted for guidance. During the wet season of the year or after any significant rainfall event, failure to obtain authorization from the local Authorized Agent for beginning construction of an onsite wastewater system may void the Onsite Wastewater System Permit. Open trenches should be protected from surface run-off to prevent the entrance of any silt and debris. If it is necessary to walk in the trench, a temporary board laid on the bottom will reduce damage by compaction. Some smearing and damage is bound to occur. All smeared or compacted surfaces should be raked to a depth of one inch, and loose material removed, before the gravel is placed in the trench. All non-perforated pipes and the distribution box must be bedded on undisturbed earth to prevent settling, lateral lines shall be surrounded by clean, graded gravel, washed rock, or other approved aggregate. The aggregate material may range in size from 1/4 inch to 1-1/2 inches.

9.11.2 Cinders, broken shell and similar material are not approved. They are usually too fine and may lead to clogging of the absorption system. The top of the gravel should be covered with untreated building paper or other approved materials before placing the earth backfill. This will help prevent the gravel from becoming clogged with the earth. An impervious covering shall not be used, as this interferes with evaporation. The top of a new absorption trench must be adequately overfilled to allow for settling.

9.11.3 Heavy machinery, exclusive of the equipment needed to install the system, shall be excluded from the absorption area unless special provision is made to support the weight. All machine grading, unless specified in the permit, is prohibited.

9.11.4 Where capping fill is incorporated into the design of a system, only track equipment may be utilized when applying the cap.

- 9.11.5 Distribution boxes/devices. A distribution box/device is required for every standard absorption system. The purpose of the box/device is to ensure equal distribution of septic tank effluent to the lateral lines. It is important that the entrance to each lateral line from the distribution box be set at the same elevation to attempt to ensure equal flow into all lines. The design of the distribution box and absorption system can be varied to meet most topographical conditions encountered, while giving proper grade and alignment for all laterals. Distribution boxes shall be sealed, bedded in concrete or gravel on undisturbed ground, and water leveled with leveling devices. All distribution boxes must have an easily removable cover to facilitate leveling, inspection, and repairs. Inlet and outlet lines at the distribution box shall be installed in such a manner as to be firmly supported and adequately sealed as approved by the authorized agent. Where the elevation across the absorption area is greater than six inches, the outlet invert (flowline) of the distribution box must be installed at an elevation equal to or greater than the finished ground elevation of the highest line of the absorption area.
- 9.11.6 Septic tanks. On sites that do not have sufficient slope to allow the distribution box to be installed as in 9.11.5, the flow line of the septic tank outlet shall be at an elevation equal to or greater than the finished ground elevation of the highest line of the absorption area.
- 9.11.7 Absorption trenches shall not start closer than 5 feet from the distribution box. A horizontal separation of 5 feet shall be required between the absorption area and tightline trench. In systems utilizing a distribution box, all lateral lines must be of the same length. All distribution devices used in conjunction with soil absorption systems must be approved by the Department prior to their use or installation.
- 9.11.8 The tightline or manifold trench must not be excavated lower than the flow line of the trench media to be installed; however, in no case will the tightline trench be excavated lower than twelve (12) inches from the ground surface.
- 9.11.9 Materials used in the construction of the onsite wastewater system shall meet the following requirements (New products may be approved by the Department as technology allows):

SOLID PIPE:

Pipe installed from the outlet tee of the septic tank to the distribution box or diversion device shall be Schedule 40 pipe for whatever distance is required to reach undisturbed soil, but in no case shall be less than ten feet. Once a solid trench bottom is achieved the Schedule 40 pipe may be adapted to SDR 35 PVC pipe or ASTM 3034 PE (polyethylene) pipe for the remaining distance to the distribution box or diversion device. SDR 35 PVC, ASTM 3034 PE or Schedule 40 PVC shall be used from the distribution box or diversion device to the perforated field line pipe.

PERFORATED DRAIN PIPES:

Perforated pipe in absorption lines shall be ASTM 2729 PVC or ASTM F-810 PE.

9.11.10 Any pipe under driveways, roadways, parking areas, or any area where traffic will pass over shall be constructed of Schedule 40 PVC, cast iron, or use a steel sleeve. A cleanout shall be located between the stubout and the septic tank.

9.11.11 House sewer lines shall be installed and maintained in accordance with the Arkansas State Plumbing Code.

10 Alternate Systems

10.1 Alternate systems outlined in this section shall not be approved as a uniform plan of development in any municipality, community, subdivision, or other developed area.

10.2 All alternate systems outlined in this section shall be installed by a licensed septic system installer. Installers may be required to attend special training sessions before being allowed to install certain types of alternate systems.

10.3 In addition to the permitting requirements outlined in Section 5 of this regulation, a Memorandum of Agreement signed by the property owner shall be submitted as part of the Onsite Wastewater System Application for all alternate systems.

10.4 The Department or its authorized agent may require the designated representative to oversee the construction of projects with unusual or rarely used designs.

10.5 Surface Discharging Systems

10.5.1 Surface discharging systems shall not be approved for sites with soil conditions, which meet the standards referenced in Sections 8.5, and 8.6 for the installation of subsurface absorption systems.

10.5.2 Prior to approval, for all sites proposed for surface discharging systems, concurrence shall be obtained from one of the following individuals in addition to the Local Authorized agent.

10.5.2.1 A Professional Soil Classifier of the Department or a designated Authorized Agent trained and proficient in soil analysis.

10.5.2.2 A private Professional Soil Classifier holding a current Designated Representative License retained at the discretion of the Permit Applicant.

10.5.3 Surface discharging systems shall not be approved in subdivisions or other high-use areas, regardless of lot size.

10.5.4 All surface discharging systems are subject to National Pollutant Discharge Elimination System (NPDES) Permit requirements.

10.5.5 Disinfection

10.5.5.1 All surface discharging systems must be adequately disinfected prior to discharge.

- 10.5.5.2 Chlorination, ozone induction, and ultraviolet exposure are all acceptable means of disinfection for surface discharges. Installation, operation and performance data supplied by the manufacturer shall be submitted with all designs incorporating ozone or ultraviolet light devices.
 - 10.5.5.3 Chlorinators used in surface discharging systems shall produce a minimum 10 parts per million chlorine solution during peak flow.
 - 10.5.5.4 A baffled contact chamber sufficient in size to provide a 30 minute retention time with a minimum flow of 1 gallon per minute shall be required after the chlorinator for all surface-discharging systems utilizing chlorine disinfection. The minimum size of a chlorine contact chamber shall be 30 gallons. A sample port must be installed at outlet end of contact chamber.
 - 10.5.5.5 The point of discharge from the chamber shall be above the high water level of a receiving stream or ditch. The chamber discharge elevation shall also be below its influent elevation to prevent flooding of the treatment unit.
- 10.5.6 When a surface discharging system fails to function properly or does not consistently meet the discharge requirements, the discharge of wastewater shall stop immediately. The owner shall be allowed to use the septic tank or mechanical treatment unit as a holding facility until adequate repairs are made.

10.5.7 Onsite Discharging Systems

- 10.5.7.1 Some sites may be adequate in size to retain all effluent discharged to the surface onsite. Sites considered for onsite discharge shall meet the following minimum requirements in addition to setback requirements outlined in Section 6.2 of this regulation.
- 10.5.7.2 The lot size for all sites proposed for onsite discharge shall be 3 acres or greater.
- 10.5.7.3 The point of discharge shall be 300 feet or greater from any adjacent dwelling.
- 10.5.7.4 The point of discharge shall be 150 feet or greater from any adjacent property line.
- 10.5.7.5 The point of discharge shall be 200 feet or greater from any property line in the direction of flow on sites exhibiting slopes of 12% or less.
- 10.5.7.6 The point of discharge shall be 100 feet or greater from the dwelling served by the surface discharging system.
- 10.5.7.7 The slope of the discharge area shall not be greater than 12%. However, variances for sites proposed for surface discharges that exhibit a slope greater than 12% may be requested of the Department in writing. Approval of such variances shall be at the sole discretion of the Department.

10.5.8 Offsite Discharging Systems

10.5.8.1 Offsite discharging systems shall not be approved for new construction.

10.5.8.2 An N.P.D.E.S. Permit is required from the Arkansas Department of Environmental Quality for all offsite discharging systems.

10.6 Holding Tanks

10.6.1 Holding tanks shall not be approved on sites acceptable for the installation of subsurface onsite wastewater systems as outlined in Sections 8.5, and 8.6 of this regulation.

10.6.2 Holding tanks shall be approved only for domestic waste from commercial establishments, excluding grocery stores and/or food service establishments.

10.6.3 Holding tanks shall not be approved for residences, full or part time.

10.6.4 The minimum capacity of any holding tank shall be ten times the estimated daily usage as outlined in Appendix C of this regulation or 1000 gallons, whichever is greater.

10.6.5 A service riser with a minimum diameter of 12 inches and installed above ground surface shall be required on all holding tanks. All service risers installed on holding tanks shall be adequately secured to prevent unauthorized access.

10.6.6 Facilities shall be maintained to allow a pumper vehicle to drive within 10 feet of the service riser in all weather conditions.

10.6.7 Proof of a notarized contract with a licensed septic tank cleaner shall be required before a permit to operate is issued. The contract shall provide for cleaning within 24 hours of notification, and shall state where the wastewater will be deposited.

10.6.8 Holding tank contents shall not be land applied. The contents of a holding tank shall only be disposed of by means of deposition into a municipal wastewater treatment plant with which the septic tank cleaner has permission to dump.

10.6.9 All holding tanks shall comply with the specifications for septic tanks outlined in Section 11 of this regulation.

10.6.10 A visible and/or audible high water alarm indicating when the tank has reached 75% capacity shall be installed inside the structure served by the holding tank. Information on the alarm system's brand name, manufacturer, use, and installation must be provided with the submittal of plans. The name of the licensed cleaner and his telephone number must be displayed on the alarm.

10.6.11 A monitoring contract is required. See Section 13

10.7 Composting/Incinerating Toilets

A composting toilet is a device specifically designed to retain and process body wastes and, in some cases, household garbage by biological degradation. The process may be either thermophilic or mesophilic, depending on the design of the toilet. Thermophilic devices are normally smaller and require some type of energy input to maintain the desired temperature. Mesophilic devices rely on the heat produced by the biological process to maintain the required temperature. Whether or not a device can accept household garbage is dependent on product design and intended use. An incinerating toilet is a device designed to reduce body wastes, both urine and feces, to an ash residue. The type of energy used to incinerate wastes is dependent upon the design of the device used.

10.7.1 Only pre-manufactured composting or incinerating toilets approved by the Department shall be utilized in the onsite wastewater system. Under NSF standard 41, all composting and incinerating devices shall be evaluated by an ANSI approved laboratory.

10.7.2 Grey water, exclusive of urine and feces, produced by the structure served by a composting/incinerating toilet shall be renovated or disposed of in accordance with Sections 9 or 10.5 of this regulation.

10.7.3 The stabilized compost from a composting toilet must be buried onsite or deposited in an approved sanitary landfill.

10.7.4 The ash from an incinerating toilet requires no special handling since any pathogen would be destroyed in the incineration process.

11 Septic Tanks

11.1 The minimum liquid capacities required in Appendix C, allow for the use of standard household appliances. Garbage grinders are not recommended for subsurface absorption systems.

11.2 Location. Consideration should also be given to the location from the standpoint of cleaning and maintenance. Septic tanks shall be so located that septic tank cleaning equipment trucks can be driven within reasonable vertical and horizontal distance of the tank for the purpose of tank cleaning. Where public sewers may be installed at a future date, provision should be made in the household plumbing system for connection to such sewer.

11.3 All septic tanks and dosing tanks used in Arkansas must be manufactured by an individual holding a current septic tank manufacturer license issued by the Department. The manufacturer is responsible for producing septic tanks, pump basins, and dosing tanks that meet all current requirements as outlined in these regulations.

11.4 The septic tank installer is responsible for inspecting the tank(s) delivered to the jobsite to ensure a licensed manufacturer produced it and that it remains in a sound, watertight condition throughout the installation. All septic tanks shall be installed and bedded on a firm, level, gravel surface. All influent and effluent lines connected to the tank must be sealed in a manner that prevents groundwater infiltration and pipe movement. Rubber or

plastic pipe penetration seals shall be either cast into the tank or installed after manufacture.

11.5 Septic Tanks no longer in use must be pumped out by a licensed septic tank cleaner, collapsed, and filled with clean material at the time of abandonment.

11.6 Specifications for septic tanks and dosing tanks.

11.6.1 General. All portions of septic tanks shall be watertight. Septic tanks shall be constructed of materials not subject to excessive corrosion decay, or leakage. Approved materials include concrete, fiberglass, and polyethylene. Approval of other materials will be considered on a case-by-case basis. All septic tanks sold in the State of Arkansas shall meet the specifications in these regulations and be approved by the Department. With exception of the wall and bottom thickness, pre-cast tanks and cast-in-place tanks shall meet the same design requirements

11.6.2 Cast-in-place concrete tanks. Cast-in-place concrete tanks shall be watertight, adequately reinforced and constructed of high strength concrete, and shall be constructed in accordance with good concrete construction practices. The minimum wall and bottom thickness for cast in place septic tanks is 5 inches and the minimum top thickness is 4 inches. Cast in place tanks must be reinforced with #10 welded wire mesh throughout. The bottom and sides must be manufactured in a single, continuous pour. The lids of cast in place tanks must be reinforced with 0.5-inch (#4 rebar) reinforcement rods on 18-inch centers in addition to the welded wire mesh.

11.6.3 Pre-cast septic tanks. All pre-cast septic tanks sold and used in Arkansas shall be manufactured in accordance with the AMERICAN SOCIETY FOR TESTING AND MATERIALS (ASTM) STANDARD SPECIFICATION FOR PRE-CAST CONCRETE SEPTIC TANKS C 1227-05-cast septic tanks shall be constructed with high strength concrete made with Portland cement and have a compressive strength of 4000 pounds / square inch at 28 days of age. No aggregate used in the concrete mix is to exceed a diameter or length of 0.5 inch. Lightweight aggregates must meet ASTM SPECIFICATION C 330 SPECIFICATION FOR LIGHTWEIGHT AGGREGATES FOR STRUCTURAL CONCRETE. Water used in mixing concrete must be clean and free of injurious amounts of oil, alkalines, acids, salts, or other substances that may be incompatible with concrete. Tanks shall be designed so they will not collapse or rupture when subjected to anticipated earth and hydrostatic pressures when the tanks are either full or empty.

11.6.3.1 Pre-cast concrete tanks shall be adequately reinforced with #10 welded concrete reinforcement wire tied at the edges and corners. Reinforcement rods are required to be added at lift points. Chairs, bolsters, braces, and spacers in contact with the forms must have a corrosion resistant surface. Reinforcement must be placed as near the center of the walls as possible and shall have a minimum of one-inch concrete cover.

11.6.3.2 The forms used in septic tank manufacture shall be sufficiently rigid and accurate to maintain the dimensions of the tank. All casting surfaces shall be of a smooth, non-porous material. Form releasing agents used shall not be injurious to the concrete.

- 11.6.3.3 Concrete for the tank walls and bottom shall be placed in the forms in a single, continuous pour. The concrete shall be placed in the forms at a rate that allows the concrete to consolidate in all parts of the form and around all reinforcement steel and imbedded fixtures without segregation of materials. The finished tank shall be smooth and have a uniform thickness not less than 2.5 inches. The top of the tank shall be no less than 3.5 inches thick and adequately reinforced to support the load to which it may be subjected. At a minimum, the lid shall be reinforced with #10 welded wire mesh and 0.5 inch reinforcement rods (#4 rebar) on 18-inch centers. Pre-cast concrete tanks shall be cured for 28 days before delivery to assure proper curing. During delivery, the tanks are to be properly handled to assure the installation of a tank that is watertight and otherwise in good condition.
- 11.6.3.4 All joints between the tank and lid and between the two sections of two-piece tanks shall be sealed to prevent leakage during settling or shifting. The sealant shall be resistant to corrosion and anaerobic activity. The inside joint seam gap, between the 2 sections placed together before sealing, is not to exceed 1/4 (0.25) inch.
- 11.6.3.5 The lid and upper and lower sections of septic tanks shall be connected with non-corrosive mechanical devices by the manufacturer to insure no separation occurs. All manufacturers shall comply with this requirement by July 1, 2009.
- 11.6.3.6 Septic tank manufacturers are required to demonstrate the water tightness on their products when requested by the system designer, installer or the authorized agent. Testing for leakage may be done using either vacuum testing or water pressure testing. Small leaks found during testing may be sealed with an appropriate sealer. In no case will a tank be considered acceptable which has evidence of large cracks or repairs that compromise the structural integrity and water tightness of the tank.
- 11.6.3.6.1 Vacuum testing. Seal the empty tank and apply a vacuum to 4 inches (100 mm) of mercury. The tank is approved if 90% of the vacuum is held for 2 minutes.
- 11.6.3.6.2 Water-pressure testing. Seal the tank; fill with water to the level of the top of the access port, let stand for 24 hours. Refill tank. The tank shall be considered water tight if the water level is held for 60 minutes.
- 11.6.3.7 All precast concrete septic tanks manufactured and used in Arkansas must be clearly, permanently, and legibly labeled with the following:
- 11.6.3.7.1 The name of the individual or company that manufactured the tank.
- 11.6.3.7.2 The liquid capacity of the tank in gallons.
- 11.6.3.7.3 The inlet and outlet must be indicated. Each septic tank shall have only one inlet and one outlet. Tanks with more than one outlet must utilize approved tank penetration seals.

11.6.3.7.4 The date of manufacture of the tank and lid.

11.6.4 Tank proportions. The liquid depth of any tank compartment shall not be less than 36 inches and shall not exceed 72 inches. The minimum horizontal distance from the inlet to the outlet of any tank may not be less than 72 inches. Storage capacity is required above the liquid line to provide for that portion of scum that floats above the liquid in all septic tanks. On the average, 30% of the total scum will accumulate above the liquid line. In addition to the provision for scum storage, one inch shall be provided at the top of the tank to permit the free passage of gas back to the inlet and house vent pipe. For tanks having vertical sides, the distance between the inside top of the tank and the liquid level shall be 12.5% of the liquid capacity or 9 inches, whichever is greater. In horizontal, cylindrical tanks, this distance should be equal to 20% of the tank diameter.

11.6.5 Inlet and outlet. Four-inch or larger sanitary tees shall be used as inlet and outlet devices in all septic tanks. The septic tank manufacturer shall provide properly constructed inlet and outlet devices with each tank. The effluent line leaving the tank shall be Schedule 40 PVC. The inlet invert shall enter the tank at least 3 inches above the liquid level in the tank to allow for a momentary rise in liquid level during discharges to the tank. This free drop prevents blackwater and standing of solid material in the house sewer leading to the tank. The inlet tee shall extend at least 6 inches below the liquid level in the tank and extend above the liquid level to a minimum of one inch from the top of the tank. In no case shall the inlet device be greater in length than the outlet device.

11.6.5.1 Outlet tees shall extend to a distance below the surface 35 to 45% of the liquid depth.

11.6.6 Approved outlet filters are recommended on all septic tanks. Outlet filters have been shown to reduce total suspended solids (TSS) and biochemical oxygen demand (BOD) and should be utilized to protect and lengthen the life of the absorption area. Proprietary gas deflectors designed to deflect or otherwise prevent solids from entering the outlet tee are not required but are recommended to increase the efficiency of the septic tank. Where gas deflectors, outlet filters, or other devices requiring routine maintenance are installed in the tank, a service riser extending to grade shall be installed over the outlet inspection port. All inlet and outlet baffles and devices must be evaluated and approved by the Department prior to use. Manufacturers may submit product samples and ancillary documentation to the Department for evaluation. After evaluation, the Department will either approve or not approve the product submitted. Lists of approved products will be routinely updated and distributed.

11.6.7 Fiberglass septic tanks. Fiberglass septic tanks shall comply with International Association of Plumbing and Mechanical Officials. The manufacturer shall supply without charge satisfactory evidence of approval and compliance with IAPMO PS 1-2004e1 construction and manufacturing requirements.

11.6.8 Service Risers. Access shall be provided over both the inlet and outlet tees or devices and to each tank compartment. All maintenance ports must be sealed and

watertight. Where the top of the tank is located below the finished grade, service risers shall extend to or above the finished grade. The extension can be made using risers of approved material and fitted with tight covers and secured to prevent unauthorized access. Proper attention must be given to the accident hazard involved when maintenance ports are extended close to the ground surface. Service risers shall be a minimum of 12 inches in diameter. Service risers providing access to a pump compartment or dosing tank shall be a minimum of 18 inches in diameter.

11.6.8.1 Service risers shall be available through the septic tank manufacturer. Risers may be installed on the tank by the manufacturer or set in place and sealed in a sanitary manner by the installer.

11.7 Grease interceptors shall be installed and maintained in accordance with the ARKANSAS STATE PLUMBING CODE. The minimum volume in gallons for a grease interceptor utilized with an onsite wastewater system shall either be 500 or the number of fixture units multiplied times a flow rate of 7.5 gallons per minute multiplied times a 12 minute retention time ($\#Fx7.5x12$), whichever is greater. Fixture units will be calculated using Arkansas State Plumbing Code. Grease interceptors installed below finished grade will be installed with service risers to the finished grade. The size of the service riser will be adequate in size to accommodate proper inspection and maintenance.

THE HOUSE SEWER:

11.8. House sewer. The house sewer is an important part of the private sewage disposal system. It should convey the sewage from the building to the septic tank inlet, but not at a high velocity that would cause disturbance in the septic tank. The house sewer shall not be reduced in size from the house drain to the septic tank. Care shall be taken to obtain a tight seal at the entrance of the house sewer into the septic tank.

11.9. House sewer grade. The grade or slope of the house sewer, which conveys the sewage to the septic tank, should be sufficient to move the sewage slowly but efficiently to the septic tank. Excessive grades will cause increased velocity into the tank and have a tendency to disrupt the settling action of the tank. Too little grade will result in sewer stoppage and a nuisance. The house sewer should be installed with a uniform slope, with not less than 1/8-inch fall per foot, and preferably not more than 1/4 inch per foot.

11.10. Cleanouts. The house sewer line shall contain a 4-inch cleanout before entering the septic tank or treatment plant. All changes in direction greater than 45 degrees and/or every 100 feet require a cleanout.

12 Secondary Treatment

Secondary treatment systems utilize an additional means of septic effluent treatment subsequent to the primary treatment performed by a septic tank. Some aerobic treatment units (ATU's) do not require that effluent be treated by a septic tank prior to treatment by the ATU. All secondary treatment units incorporated into the design of an onsite wastewater system shall comply with the following specifications.

12.1 Effluent treated by a secondary treatment unit shall be further renovated or discharged in accordance with either Section 9 or Section 10.5 of this regulation.

12.2 The discharge from all secondary treatment units shall meet current N.P.D.E.S. discharge requirements.

12.3 All onsite wastewater systems incorporating secondary treatment units shall comply with the Onsite Maintenance and Monitoring Program outlined in Section 13 of this regulation.

12.4 Aerobic Treatment Units (ATUs)

12.4.1 Only ATUs approved by the Department shall be utilized in onsite wastewater systems. All ATUs must meet current American National Standards Institute/National Sanitation Foundation (ANSI/NSF) Standard 40 requirements.

12.4.2 ATUs shall be installed according to the manufacturer's specifications as approved by the Department. ATUs shall be installed as provided in Section 11.4. Some ATUs require installer certification provided by the manufacturer in order to install and/or maintain the unit.

12.5 Single Pass Filters

12.5.1 Intermittent Sand Filters (ISFs)

12.5.1.1 Intermittent Sand Filters pass effluent treated by a septic tank or ATU through a sand and gravel bed, built on site, prior to subsurface absorption or surface discharge. Intermittent sand filters shall meet the following criteria.

12.5.1.2 A septic tank or ATU shall be required as the primary treatment of effluent prior to treatment by an ISF.

12.5.1.3 Effluent shall be dosed to the ISF by a pump housed in a filtered pump vault approved by the Department.

12.5.1.4 Effluent shall be distributed to the ISF by means of low pressure distribution grid constructed as outlined in Section 9.10 of this regulation.

12.5.1.5 The collection line in the bottom of an ISF shall not be less than 4 inch perforated or slotted schedule 40 PVC pipe.

12.5.1.6 The dosing rate for ISFs shall not be greater than 0.25 gallons per orifice per dose (gal/orifice/dose).

12.5.1.7 The loading rate for ISFs shall not be greater than 1.25 gallons per square foot per day (gal/ft²/day).

12.5.1.8 ISFs may be installed either in or above ground. However, the top of the ISF bed shall not be installed below the finished grade of the ground surface.

- 12.5.1.9 A PVC liner not less than 30 mils in thickness, with inlet and outlet boots shall be required in all ISFs in order to minimize groundwater infiltration into the system.
- 12.5.1.10 Not less than 2 inches of gravel cover shall be applied atop the collection pipe in the bottom of an ISF. The gravel used shall be crushed rock or rounded rock, 1.0 inch to 2.5 inches in diameter.
- 12.5.1.11 Not less than 4 inches of 3/8-inch pea gravel shall be applied atop the crushed or rounded rock in the bottom of an ISF in order to prevent migration of filter sand into the collection piping and out of the filter.
- 12.5.1.12 Not less than 24 inches of filter sand shall be applied atop the pea gravel in the bottom of the ISF. Filter media used shall be 0.28 millimeters to 1.0 millimeter in diameter, with a uniformity coefficient of 4.0.
- 12.5.1.13 Not less than 3 inches of 3/8-inch pea gravel shall be applied atop the filter sand in an ISF. The low pressure distribution system servicing an ISF shall be installed atop this layer of pea gravel.
- 12.5.1.14 Not less than 3 inches of 3/8-inch pea gravel shall be installed as cover over the low pressure distribution system servicing an ISF.
- 12.5.1.15 No greater than 6 inches of soil cover shall be applied to the surface of the gravel and sand bed in order to minimize odor produced by an ISF. Polyester spun fabric shall be installed atop the filter bed prior to the application of the soil cover in order to prevent the migration of the soil cover into the filter bed.

12.6 Multiple Pass Filters

12.6.1 Recirculating Sand Filters (RSFs)

- 12.6.1.1 Recirculating Sand Filters pass effluent treated by a septic tank or ATU through a sand and gravel bed, built on site, prior to subsurface absorption or surface discharge. Recirculating sand filters shall meet the following criteria:
- 12.6.1.2 A septic tank or ATU shall be required as the primary treatment of effluent prior to treatment by an RSF.
- 12.6.1.3 Effluent shall be dosed to an RSF by a pump housed in a filtered pump vault approved by the Department.
- 12.6.1.4 Effluent shall be distributed to an RSF by means of low pressure distribution as outlined in Section 9.10 of this regulation.
- 12.6.1.5 The collection line in the bottom of an RSF shall not be less than 4 inch perforated or slotted schedule 40 PVC pipe.
- 12.6.1.6 The dosing rate for RSFs shall not be greater than 0.25 gallons per orifice per dose (gal/orifice/dose).

- 12.6.1.7 The initial recirculation rate for RSFs shall be 4:1. Depending upon water usage, the recirculation rate may be adjusted after system evaluation.
- 12.6.1.8 The loading rate for RSFs shall not be greater than 5 gallons per square foot per day (gal/ft²/day).
- 12.6.1.9 RSFs may be installed either in or above ground. However, the top of the RSF bed shall not be installed below the finished grade of the ground surface.
- 12.6.1.10 A PVC liner not less than 30 mils in thickness, with inlet and outlet boots shall be required in all RSFs in order to minimize groundwater infiltration into the system.
- 12.6.1.11 Not less than 2 inches of gravel cover shall be applied atop the collection pipe in the bottom of an RSF. The gravel used shall be crushed rock or rounded rock, 0.5 inch to 1.5 inches in diameter.
- 12.6.1.12 Not less than 4 inches of 3/8-inch pea gravel shall be applied atop the crushed or rounded rock in the bottom of an RSF in order to prevent migration of filter sand into the collection piping and out of the filter.
- 12.6.1.13 Not less than 24 inches of filter sand shall be applied atop the pea gravel in the bottom of an RSF. Filter media used shall be 1.5 millimeters to 2.5 millimeters in diameter, with a uniformity coefficient of 2.0 or less.
- 12.6.1.14 Not less than 3 inches of 3/8-inch pea gravel shall be applied atop the filter sand in a RSF. The low pressure distribution system servicing an RSF shall be installed atop this layer of pea gravel.
- 12.6.1.15 Not less than 3 inches of gravel shall be installed as cover over the low pressure distribution system servicing an RSF.
- 12.6.1.16 The top of the RSF filter bed shall be left uncovered.

12.7 Other Filters

Proprietary media filters such as peat filters, gravel filters, and geo-textile filters shall be designed and installed in accordance with the manufacturer's specifications as approved by the Department.

13 Onsite Maintenance and Monitoring Program

Owners of Onsite and Offsite Surface Discharging Systems, which include alternate systems discharging into reduced absorption areas or Holding Tanks, are required to maintain a Maintenance and Monitoring Contract with Maintenance Person registered by the Department for the life of the system. A Maintenance Person shall be authorized by the manufacturer in order to provide a contract for the maintenance and monitoring of any proprietary system. No home owner shall be allowed to monitor their own system.

- 13.1 The Maintenance and Monitoring Contract and the Memorandum of Agreement shall be submitted with the Application for an Onsite Wastewater System Permit (EHP-19).
- 13.2 All Maintenance and Monitoring Contracts shall include the following minimum terms or services:
- Frequency of system assessments
 - Assessment of system components
 - Assessment of discharge route for surface discharge systems
 - Measurement of free chlorine residual, if applicable
 - Assessment of proper servicing of grease interceptor, if applicable
 - Reporting to the Arkansas Department of Health
- 13.3 Assessments shall be conducted for all systems maintained and monitored under the program a minimum of once every 6 months.
- 13.4 Free chlorine residual will be measured and recorded from the outlet end of the contact chamber. If the free chlorine residual is less than 0.1 parts per million, collection of a fecal coliform sample is required within acceptable limits, as specified the National Pollutant Discharge Elimination System (NPDES) discharge parameters, before returning to a routine schedule.
- 13.5 Where ozone, ultraviolet, or other disinfection methods that do not produce a chlorine residual are incorporated in the system, annual fecal analysis of the discharged effluent shall be required.
- 13.6 Maintenance and Monitoring Contracts with Certified Maintenance Personnel with additional monitoring terms and services may be required by the department for approval of systems permitted under the variance and experimental sections 3.1 and 3.2
- 13.7 Onsite Maintenance and Monitoring reports shall be submitted to the homeowner, local health unit, and the Department's database. Certified Maintenance Personnel shall maintain a copy for their records.
- 13.8 Maintenance personnel shall be registered by the Department. To maintain certification, Onsite Maintenance Personnel shall pay a fifty dollar (\$50.00) annual fee and attend an annual training session. Failure to pay the registration renewal fee by March 1 shall result in a late fee equal to one half of the renewal fee.

14 Designated Representatives

- 14.1 A fee of one-hundred (\$100.00) shall be levied annually for the registration of each Designated Representative. Each Designated Representative who operates within the State of Arkansas, regardless where their home office may be, must be registered by the Department. The registration will be issued by the Department upon successful completion of an examination and compliance with the provisions of the Rules and Regulations. In order to maintain registration, a Designative Representative must attend

at least one (1) annual training course approved by the Department prior to March 1 and continue to demonstrate competency in practice to ensure the purpose of this regulation. Registration renewal fees shall be renewable on January 1 of each year. Failure to pay the registration renewal fee by March 1 shall result in a late fee equal to one half of the renewal fee. Failure to pay the registration renewal fee within a calendar year or failure to attend an approved training course by March 1 shall require re-examination in order to become registered.

14.2 The Designated Representative's license may be revoked or suspended whenever any provision of these Rules and Regulations is violated pursuant unto the Arkansas Administrative Procedures Act. Each Designated Representative must furnish proof of current registration upon request by an authorized agent of the Department.

15 Installers

15.1 Each installer who operates within the State of Arkansas, regardless of wherever the home office may be, must be registered by the Department. The registration will be issued by the Department or its authorized agent upon successful completion of an examination and compliance with the provisions of the Rules and Regulations. A registered installer shall be present at the job site during all phases of system construction. In order to maintain registration, an installer must attend at least one (1) annual training course approved by the Department prior to March 1 and continue to demonstrate competency in practice to ensure the purpose of this regulation. The registration shall be renewable on January 1 of each year. Failure to renew by March 1 shall result in a late fee equal to one half of the renewal fee. Failure to renew within a calendar year shall require re-examination in order to become registered. Installers licensed at the time of the effective date of this regulation will be exempt from the initial examination.

15.2 The installer's license may be revoked or suspended whenever any provision of these Rules and Regulations is violated pursuant unto the Arkansas Administrative Procedures Act. Each installer must furnish proof of current registration upon request by an authorized agent of the Department.

15.3 It shall be a violation of these Rules and Regulations for an installer to start the actual construction, alteration, repair or extension of any onsite wastewater system without first notifying the Department or its authorized agent 24 hours in advance.

15.4 Installer's registration fee. A fee of one-hundred dollars (\$100.00) shall be levied annually for the registration of each installer. The registration fee shall be made payable to the Arkansas Department of Health and shall be attached to the completed APPLICATION and forwarded to the Arkansas Department of Health.

16 Manufacturers

All septic tank manufacturers doing business in Arkansas must hold a valid registration issued by the Department. A registration fee of one hundred dollars (\$100.00) will be levied annually, payable by July 1st. An annual inspection is required for registration renewal.

17 Penalties

Any person, firm, corporation or association who violates any of the provisions of Act 402 of 1977, as amended, or any Rules and Regulations promulgated under the authority of Act 402 of 1977, as Amended, shall upon conviction, be deemed guilty of a misdemeanor and shall be punished by a fine of not less than one hundred dollars (\$100.00) nor more than one thousand dollars (\$1,000.00). Installers, Designated Representatives and Septic Tank Manufacturers who do not renew their licenses prior to 60 days after the annual expiration date will be charged a late fee equal to one half (1/2) the annual fee.

18 Severability

If any provisions of these Rules and Regulations, or the application thereof to any person is held invalid, such invalidity shall not affect other provisions or applications of these Rules and Regulations which can effect without the invalid provisions of application, and to this end the provisions hereto are declared to be severable.

19 Repeal

All Regulations and parts of Regulations in conflict herewith are hereby repealed.

20 Certification

This will certify that the foregoing Rules and Regulations Pertaining to Onsite Wastewater Systems, Designated Representatives and Installers were adopted by the Arkansas Board of Health at a regular executive session of said Board held in Little Rock, Arkansas, on the ____ day of 2010.

Paul K. Halverson, DrPH,
Director
Arkansas Department of Health

Dated at Little Rock, Arkansas, this ____ day _____, 2010.

The foregoing Rules and Regulations, copy having been filed in my office, are hereby approved this _____ day of _____, 2010.

Mike Beebe
Governor

Appendix A

Absorption Area Requirements

Percolation Rate (Minutes required for water to drop 1 inch in prepared test hole)	Loading Rate (Required gallon of effluent per square foot per day)
10-15	.75
16-20	.69
21-25	.63
26-30	.59
31-35	.56
36-40	.53
41-45	.50
46-50	.48
51-56	.45
56-60	.42
61-65	.40
66-70	.38
71-75	.37

TABLE 1**LOADING RATES FOR RESIDENCES AND COMMERCIAL ESTABLISHMENTS****A. SOILS WITH A MODERATE HYDRAULIC CONDUCTIVITY**

SEASONAL WATER TABLE (SWT) DEPTH	BRIEF SWT GPD/Sq. Ft.		MODERATE SWT GPD/Sq. Ft.		LONG SWT GPD/Sq. Ft.	
	8 Ft. Centers	10 Ft. Centers	8 Ft. Centers	10 Ft. Centers	8 Ft. Centers	10 Ft. Centers
8	0.00	0.00	0.00	0.00	0.00	0.00
9	0.03	0.03	0.01	0.01	0.00	0.00
10	0.06	0.06	0.02	0.02	0.01	0.01
11	0.10	0.10	0.03	0.03	0.02	0.02
12	0.16	0.16	0.05	0.05	0.03	0.03
13	0.22	0.22	0.07	0.07	0.04	0.04
14	0.29	0.29	0.10	0.10	0.05	0.05
15	0.40	0.40	0.13	0.13	0.07	0.07
16	0.51	0.51	0.17	0.17	0.09	0.09
17	0.62	0.63	0.21	0.21	0.11	0.11
18	0.73	0.75	0.24	0.26	0.12	0.13
19	0.75	0.75	0.28	0.30	0.14	0.15
20	0.75	0.75	0.32	0.35	0.17	0.18
21	0.75	0.75	0.36	0.40	0.19	0.20
22	0.75	0.75	0.40	0.44	0.21	0.23
23	0.75	0.75	0.44	0.49	0.23	0.25
24	0.75	0.75	0.48	0.54	0.25	0.28
25	0.75	0.75	0.52	0.59	0.26	0.30
26	0.75	0.75	0.57	0.64	0.28	0.32
27	0.75	0.75	0.60	0.68	0.30	0.34
28	0.75	0.75	0.64	0.73	0.32	0.36
29	0.75	0.75	0.67	0.75	0.34	0.39
30	0.75	0.75	0.71	0.75	0.35	0.41
31	0.75	0.75	0.75	0.75	0.37	0.43
32	0.75	0.75	0.75	0.75	0.39	0.46
33	0.75	0.75	0.75	0.75	0.41	0.48
34	0.75	0.75	0.75	0.75	0.43	0.50
35	0.75	0.75	0.75	0.75	0.45	0.53
36	0.75	0.75	0.75	0.75	0.47	0.55
37	0.75	0.75	0.75	0.75	0.49	0.58
38	0.75	0.75	0.75	0.75	0.51	0.60
39	0.75	0.75	0.75	0.75	0.53	0.63
40	0.75	0.75	0.75	0.75	0.55	0.65
41	0.75	0.75	0.75	0.75	0.57	0.68
42	0.75	0.75	0.75	0.75	0.59	0.70
43	0.75	0.75	0.75	0.75	0.61	0.73
44	0.75	0.75	0.75	0.75	0.63	0.75
45	0.75	0.75	0.75	0.75	0.65	0.75
46	0.75	0.75	0.75	0.75	0.68	0.75
47	0.75	0.75	0.75	0.75	0.70	0.75
48	0.75	0.75	0.75	0.75	0.72	0.75
49	0.75	0.75	0.75	0.75	0.75	0.75

B. SOILS WITH HIGH HYDRAULIC CONDUCTIVITY

SEASONAL WATER TABLE (SWT) DEPTH	BRIEF SWT GPD/Sq. Ft.		MODERATE SWT GPD/Sq. Ft.		LONG SWT GPD/Sq. Ft.	
	8 Ft. Centers	10 Ft. Centers	8 Ft. Centers	10 Ft. Centers	8 Ft. Centers	10 Ft. Centers
8	0.00	0.00	0.00	0.00	0.00	0.00
9	0.03	0.03	0.01	0.01	0.00	0.00
10	0.08	0.08	0.03	0.03	0.01	0.01
11	0.14	0.14	0.05	0.05	0.02	0.02
12	0.23	0.23	0.08	0.08	0.04	0.04
13	0.33	0.34	0.11	0.11	0.05	0.06
14	0.42	0.46	0.14	0.15	0.07	0.07
15	0.54	0.60	0.18	0.20	0.09	0.10
16	0.66	0.75	0.23	0.24	0.11	0.12
17	0.79	0.90	0.27	0.29	0.13	0.15
18	0.91	1.05	0.30	0.35	0.15	0.17
19	1.04	1.21	0.35	0.40	0.17	0.20
20	1.17	1.25	0.39	0.46	0.20	0.22
21	1.25	1.25	0.44	0.51	0.22	0.25
22	1.25	1.25	0.48	0.56	0.25	0.28
23	1.25	1.25	0.53	0.62	0.27	0.31
24	1.25	1.25	0.58	0.68	0.30	0.34
25	1.25	1.25	0.62	0.74	0.31	0.37
26	1.25	1.25	0.67	0.80	0.34	0.40
27	1.25	1.25	0.72	0.85	0.36	0.43
28	1.25	1.25	0.76	0.91	0.38	0.45
29	1.25	1.25	0.81	0.96	.040	0.48
30	1.25	1.25	0.85	1.02	0.43	0.51
31	1.25	1.25	0.90	1.08	0.45	0.54
32	1.25	1.25	0.95	1.14	0.47	0.57
33	1.25	1.25	1.00	1.20	0.50	0.60
34	1.25	1.25	1.05	1.25	0.52	0.63
35	1.25	1.25	1.10	1.25	0.55	0.66
36	1.25	1.25	1.15	1.25	0.57	0.69
37	1.25	1.25	1.20	1.25	0.60	0.73
38	1.25	1.25	1.25	1.25	0.63	0.76
39	1.25	1.25	1.25	1.25	0.65	0.79
40	1.25	1.25	1.25	1.25	0.68	0.83
41	1.25	1.25	1.25	1.25	0.71	0.86
42	1.25	1.25	1.25	1.25	0.74	0.90
43	1.25	1.25	1.25	1.25	0.76	0.93
44	1.25	1.25	1.25	1.25	0.79	0.97
45	1.25	1.25	1.25	1.25	0.82	1.01
46	1.25	1.25	1.25	1.25	0.85	1.04
47	1.25	1.25	1.25	1.25	0.88	1.08
48	1.25	1.25	1.25	1.25	0.91	1.12
49	1.25	1.25	1.25	1.25	0.95	1.16
50	1.25	1.25	1.25	1.25	0.98	1.20
51	1.25	1.25	1.25	1.25	1.01	1.24
52	1.25	1.25	1.25	1.25	1.04	1.25
53	1.25	1.25	1.25	1.25	1.08	1.25
54	1.25	1.25	1.25	1.25	1.11	1.25
55	1.25	1.25	1.25	1.25	1.14	1.25
56	1.25	1.25	1.25	1.25	1.18	1.25
57	1.25	1.25	1.25	1.25	1.21	1.25
58	1.25	1.25	1.25	1.25	1.25	1.25

Appendix B

QUANTITIES OF WASTEWATER FLOW FOR VARIOUS TYPES OF ESTABLISHMENTS

ESTABLISHMENT TYPE	GALLONS PER DAY
Airports, bus terminals, train stations	
Per passenger	5
Add per employee per 8 hour shift	20
Barber & beauty shops per chair	100
Bowling alleys	
Toilet wastes per lane	100
For food service, add restaurant usage below	
Camps	
Campground with central comfort stations per camper	35
Day camps (no meals served) per camper	15
Per non resident camper	50
Per resident camper or employee	75
Churches	
Per seat/no food service	5
For food service, add restaurant usage below	
For daycares, add school usage below	
Commercial establishments	
Per 100 square feet of floor space	10
Add per 100 square feet of deli floor space	50
Add per 100 square feet of bakery floor space	50
Add per 100 square feet of meat market floor space	100
Country clubs	
Per resident member	100
Per non-resident member	25
Dentists offices	
Per wet service chair	200
Add per non wet service chair	50
Doctors office	
Per practitioner	250
Add per employee per 8 hour shift	20
Factories, exclusive of industrial waste	
Gallons per employee per 8 hour shift	
No showers provided	20
Showers provided	35
Hospitals	
Per bed space	200
For food service excluding patients, add restaurant usage below	
Hotels & Motels	
Regular per room	150
Resort hotels & cottages	75
Add for establishments with self service laundry facility per machine	750

Institutions per meal served per day	65
Mobile home parks	
per single wide mobile home space	300
per double wide mobile home space	450
Nursing homes, rest homes, adult congregate living facilities	
Per bed	100
Add for food service (see Institutions, this chart)	
Office buildings per employee per 8 hour shift	15
Parks, public picnic	
Toilets only per person	5
With bath house, showers, & toilets per person	10
Recreation vehicle park	
Recreational vehicle space for overnight stay, without water & sewer hookup per vehicle space	75
Recreational vehicle space for overnight stay, With water & without sewer hookup per vehicle space	100
Recreational vehicle space for overnight stay, with water & sewer hookup per vehicle space	150
Restaurants	
Per day per seat	40
Using single service articles only per seat	25
Bar and cocktail lounge per seat	30
Carry out only	
Per meal served without public restrooms	5
Per meal served with public restrooms	10
Add per employee per 8 hour shift	15
Residences	
Single or multiple family per dwelling unit	
1 bedroom	150
2 bedroom	270
3 bedroom	370
4 bedroom	450
For each additional bedroom add	50
Rooming houses per occupant space	75
Schools per student	
Day schools & day cares	15
Add for food service	5
Add for day school workers	20
Boarding schools	75
Service stations & convenience stores	
Per vehicle served	10
Food service, per meal served	5
Stadiums, race tracks, ball parks per seat	5
Swimming pools and bathhouses per patron	10
Theaters	
Indoor, movies/auditorium per seat	5
Outdoor, drive-ins per space	10

Veterinary clinic	
Per practitioner	250
Add per employee per 8 hour shift	20
Add per kennel, stall, or cage	20

FOOTNOTES:

The estimated flows for residential systems assume a maximum occupancy of 2 persons per bedroom. Where residential care facilities (non-institutional) will house more than 2 persons in any bedroom, estimated flows are to be increased by 75 gallons per each additional occupant.

Waste from food service operations is commercial in nature and may require special system sizing and treatment/disposal considerations. For food service operations, kitchen wastewater flows are normally to be calculated at 66% of the total wastewater flow.

Systems serving high volume establishments, such as fast food restaurants, convenience stores, and service stations require special sizing consideration due to above average wastewater volume expected from restroom facilities.

Residential Strength Wastewater as the primary sewage effluent from a septic tank must not exceed the following parameters: Five-Day Biochemical Oxygen Demand (BOD₅) of 300 mg/L; Total Suspended Solids (TSS) of 200 mg/L; and Fats, Oil and Grease of 25 mg/L. Other contaminants may also be present in the wastewater; however, they shall not exceed the concentrations or quantities normally found in residential sewage.

Appendix C

MINIMUM CAPACITY OF SEPTIC TANKS

LIQUID CAPACITY OF TANK (GALLONS)

NUMBER OF BEDROOMS	RESIDENTIAL	COMMERCIAL
1, 2, and 3	1000	Capacity equal to 48 hour flow
4	1250	Minimum 1000

Note: For each additional bedroom add 250 gallons.

Appendix D

Requirements for the Approval of Residential Aerobic Treatment units for Distribution in Arkansas.

Aerobic Treatment units may be used for treating domestic wastewater waste, provided that each unit is installed, operated and maintained in conformance with the following provisions:

1. Aerobic treatment systems designed to treat up to 2,000 gallons of wastewater waste per day shall be tested and listed by an American National Standards Institute (ANSI) certified third party previously approved by the Department. Aerobic treatment units shall be in compliance with the standards for Class I systems as defined by the ANSI/NSF Standard Number 40 (revised 2005).
2. The following additional requirements shall also apply to the construction, design, and operation of aerobic treatment units treating 2,000 gallons per day or less:
 - a. A visual and audio warning device shall be installed in a conspicuous location so that activation of the warning device will alert property occupants of aerobic unit malfunction or failure. The wiring device shall be wired separately from the ATU so that the disconnecting the ATU from the electrical supply will activate the alarm.
 - b. Each unit shall be designed or equipped so that regardless of unusual patterns or frequencies of wastewater flow into the system effluent discharged will be in compliance with Class I effluent quality standards as defined by the General NPDES Permit ARG550000, Discharges From Individual Home Treatment Facilities.
 - c. The minimum required treatment capacities for systems serving any structure, building or group of buildings; shall be based on estimated daily wastewater flows as determined by the Rules and Regulations Pertaining to Onsite Wastewater Systems, Designated Representatives, and installers.

Appendix E

Requirements for becoming an Aerobic Treatment Unit Distributor

The following items are required to become a distributor of aerobic treatment units used for domestic wastewater treatment. Application is made to the Department:

1. A current septic tank installer's license, septic tank manufacturer's license, or a designated representative's license.
2. Factory trained installation and service personnel capable of providing service within 48 hours. Service personnel must also be currently licensed by the Department as a Certified Maintenance Person.
3. A statement from the National Office stating that in the event of the local franchise going out of business, the service contracts in Arkansas will be honored and renewed by another franchise in an adjoining state or region of Arkansas.
4. Provide orientation seminars to Certified Maintenance Personnel and provide parts and seminars to installers certified to repair aerobic treatment units.

Appendix F

Requirements for Submission of an Onsite Wastewater System Permit Application

1. All items will be submitted in triplicate to the local health unit with the permit fee
2. Completed Onsite Wastewater System Permit Application Form.
3. Vicinity Map.
4. The drawing to be to scale using either 1 inch = 20 feet or 1 inch = 30 feet. The drawing must indicate the house, all onsite wastewater system components, and all other features affecting the location of primary and secondary absorption areas.
5. The direction of North is to be indicated.
6. Property lines must be defined and their dimensions shown. Dimensions that cannot be indicated by scale must be designated by a shown distance between 2 indicated points. The distance to 2 adjacent property lines must be shown to tie the system to one location on the lot.
7. All onsite wastewater system setbacks and their distances must be shown. Structures and their dimensions and all features which affect the locations of system setbacks including the location of utility/service lines must be shown.
8. The driveway and parking area dimensions must be shown.
9. The location and elevation of the water well must be shown along with their distance from all parts of the onsite wastewater system and secondary absorption area. For public water systems, show the distances from the onsite wastewater system's components and secondary absorption area location to the water mains and the water service lines.
10. The location, elevation and distances of all wells and/or onsite wastewater systems on adjoining properties that are within 100 feet of the proposed septic system and secondary absorption area must be shown.
11. Locate and properly size the primary and secondary absorption area and include contour lines or arrows indicating the direction and degree of the lot's slope must be shown.
12. A benchmark must be designated and elevation shots or rod readings must be shown for all parts of the wastewater system. Ground elevation and flow-line elevations must be provided for all system components. This includes the stub-out and the beginning, middle and end of each absorption trench. Each absorption trench shall be designed on contour, not to exceed 2 inches difference in elevation from beginning to end.
13. The tank sizes and locations must be indicated.

14. Unusual soils or topographies that affect the site must be shown and identified. Examples include: excavations, ponds, streams, rock outcrops, drainages, government take lines, etc.
15. The location of percolation test holes on the property must be shown. All percolation test holes used in determining the absorption area size must be within the primary absorption area location.
16. The location of all soil pits on the property must be shown.
17. The flow line elevation of the building sewer stub-out must be indicated on the plans. The flow line elevations of all tank inlets and outlets must be provided. The flow line elevation of the distribution box/device must be provided.
18. The location of the clean out(s) must be shown.
19. Pipe specifications for all parts of the system must be provided.
20. The absorption trench depth must be indicated.
21. The absorption trench media/product must be indicated.
22. Soil information including hydraulic conductivity, redoximorphic features and depth to bedrock found in the primary and secondary absorption areas from the soil pit must be provided.
23. Pumped effluent systems
 - a. All pertinent data required for conventional system must be provided.
 - b. Indicate the calculated dose volume.
 - c. Provide the construction details and inside dimensions on the dose tank.
 - d. Indicate the length and diameter of the pumped effluent line.
 - e. Indicate the length and diameter of the pipe from dose chamber to the distribution system.
 - f. Indicate the elevation difference between the inlet to the distribution system and pump's shut-off elevation.
 - g. Provide the brand, model number and pump curve of effluent pump specified. Include the calculations used to determine the dose volume per minute and friction head. Provide details of the pump control assembly.
24. Indicate the diversion device to be used and its location.
25. Systems included in the Onsite Maintenance Program must be submitted with a valid contract with a Certified Maintenance Provider.

DR RESPONSIBILITIES IN APPLICATION SUBMITTAL

The Designated Representative (DR) submits a completed Individual Sewage Disposal System Permit Application (EHP-19) along with detailed plans, specifications, and required fees. This application package is submitted to the appropriate Environmental Health Specialist and/or Local Health Unit.

The following information must be provided on the Individual Sewage Disposal System Permit Application (EHP-19). The requirements for each item are explained below.

The type of application being requested is indicated by checking the appropriate box in the upper right corner of the EHP-19. The permit choices are:

NEW INSTALLATION – Any individual sewage system that has not been permitted.

ALTERATION/REPAIR

Alteration - Any change or extension to an existing, permitted system.

Repair - The restoration of a malfunctioning system to proper function.

The fee amount is calculated from the chart in the upper right corner of the EHP-19 and marked with a check in the appropriate box.

In the first block of Part I (Treatment Type), check the Treatment Type proposed. If the Treatment Type is not listed on the EHP-19, mark Other (OTH).

In the second block of Part I (Disposal Method), check the Disposal Method proposed. If the Disposal Method is not listed on the EHP-19, mark Other (OTH).

The information required for items 1-22 is explained by the item's number as found on the EHP-19:

1. The name of the home or building owner. If the structure is a "spec house," the builder's name can be used, but the homeowner's name should be added prior to the final inspection.
2. The telephone number of the person listed in item 1. This is required in the event the Environmental Health Specialist needs to discuss an issue with the property owner.
3. The mailing address of the person listed in item 1.
4. The county in which the proposed system is located.
5. The address of the proposed system. If a 911 address is not available, simple and accurate directions are required.

6. The name of the subdivision the system is located in. If the proposed system site is not located in a subdivision, mark this space with N/A.
7. The date that the subdivision in item 6 was approved by the Department of Health.
8. The date the subdivision in item 6 was recorded at the county courthouse. If the subdivision was not recorded, mark this space with "not recorded." If the subdivision was filed and recorded prior to July 1, 1977, the permit may be reviewed under either the current regulations or the applicable Bulletin #9. This must be addressed on the permit application. If not applicable, mark this space with N/A.
9. The subdivision lot number of the proposed system. If not applicable, mark this space with N/A.
10. The dimensions, in feet, of the property. These dimensions must correspond to the dimensions shown on the plat drawing. The dimensions must be entered. Do not refer to the plat drawing.
11. The total area of the lot in acres.
12. For residential systems, list the total number of bedrooms. For non-residential systems, list the number of people using the system on a daily basis.
13. Indicate the estimated daily flow in gallons per day (GPD). For residential systems, the gallons per day per bedroom rates used to design the system must be stated. Non-residential systems are based on Appendix B, Quantities of Sewage Flow for Various Types of Establishments, which can be found in the Rules and Regulations Pertaining To Sewage Disposal Systems, Designated Representatives and Installers.
14. Provide a brief legal description for the site of the proposed system. The legal description should be taken down to a minimum of two and one-half (2 ½) acres.
15. Indicate whether the site will be supplied water by either a public water system or a private well. If the water will be from a public system, list the name of the supplier.
16. Indicate the GPS coordinates (longitude and latitude) of the center of both the primary and secondary disposal sites or the point of discharge, whichever is appropriate.
17. When soil properties are used to design the system, the DR completes item 17, a-h. When percolation tests are used to design the system, the DR records the information for item 17, a-d. Item 17, e-h, are then marked N/A. All boxes must be filled out. Do not leave blank spaces. If a box is not needed, mark N/A. Item 17 is the soil information for the primary disposal site.

- a. Record the depth, in inches, to bedrock. For the definition of bedrock, refer to the Department of Health's Bedrock policy.
 - b. Record the depth, in inches, to the observed brief seasonal watertable.
 - c. Record the depth, in inches, to the observed moderate seasonal watertable.
 - d. Record the depth, in inches, to the observed long seasonal watertable.
 - e. Record the depth, in inches, to the adjusted moderate seasonal watertable.
 - f. Record the depth, in inches, to the adjusted long seasonal watertable.
 - g. Record the class and depth of the hydraulic conductivity used to design the system.
 - h. Record the loading rate, in gallons per square foot per day, used in the system design.
18. Record the soil information for the secondary disposal site using the same directions as item 17.
19. This item is applicable when percolation tests are used to size the absorption system. Record the percolation rates as indicated. The percolation rate for the alternate secondary area is **not** used in finding the average percolation rate.
20. Record the size/dimensions of the proposed system's components.
- a. Record the liquid capacity, in gallons, of the septic tank to be used.
 - b. Record the liquid capacity of the dose tank, in gallons, to be used. If no dose tank is required, mark N/A.
 - c. Record the size, in square feet, of the absorption area required.
 - d. Record the number of absorption trenches to be used.
 - e. Record the length of the absorption trenches. If the absorption trenches are of different lengths, record all lengths used. Absorption trenches of different lengths are only allowed for serial distribution and pressure distribution designs. If more space is needed, use 20, h.
 - f. Record the depth, in inches, at which the proposed absorption trenches are to be installed.
 - g. Indicate the minimum absorption trench spacing, center to center, to be used.
Remarks. This space is provided for any additional information the DR deems pertinent.
21. Trench media.
22. Fill out as indicated. With the exception of the DR's signature, all information in this box must be either typed or printed.

23. The Environmental Health Specialist responsible for the system review completes this item.

24. The signature of the person whose name appears in item 1.

These items shall be on or provided with the plot drawing.

1. A Vicinity Map.
2. The drawing to be to scale using either 1 inch = 20 feet or 1 inch = 30 feet. The drawing must indicate the house, all septic system components, and all other features affecting the location of primary and alternate secondary disposal locations.
3. The direction of North must be indicated.
4. Property lines must be defined and their dimensions shown. Dimensions which cannot be indicated by scale must be designated by a shown distance between two indicated points. The distance to two adjacent property lines must be shown to tie the system to one location on the lot.
5. Structures and their dimensions must be shown. All features must be shown which affect the locations of system setbacks, including the location of utility/service lines.
6. The driveway and parking area dimensions must be shown.
7. The location and elevation of the water well and water supply line must be shown, along with their distance from all parts of proposed septic system location and alternate disposal location. For public water systems, show the distances from the septic system's components and alternate secondary disposal location to the water mains and the water service lines.
8. The location, elevation and distances of all wells and/or septic systems on adjoining properties that are within 100 feet of the proposed septic system and alternate secondary area must be shown.
9. All septic system setbacks and their distances must be shown.
10. In the primary and alternate (~~secondary~~) disposal site locations, contour lines or arrows indicating the direction and degree of the lot's slope must be shown.
11. A bench-mark must be designated and elevation shots or rod readings must be shown for all parts of the sewage system. Ground elevation and flow-line elevations must be provided for all system components. This includes the stub-out and the beginning, middle and end of each absorption trench in the primary and alternate (~~secondary~~) disposal sites

12. The septic tank size and location must be indicated.
13. Unusual soils or topographies that affect the site must be shown and identified. Examples include: excavations, ponds, streams, rock outcrops, drainages, government take lines, etc.
14. The location of percolation test holes on the property must be shown. All percolation test holes used in determining the absorption field size must be within 10 feet of primary disposal field location.
15. The location of all soil pits on the property must be shown.
16. The flow line elevation of the building sewer stub-out must be indicated on the plans. The flow line elevations of septic tank inlet and outlet must be provided.
17. The location of the clean-out(s) must be shown.
18. Pipe specifications for all parts of the system must be provided.
19. The primary absorption area must be properly sized.
20. The absorption trench depth must be indicated.
21. The alternate secondary area must be indicated and properly sized.
22. The soil determination, percolation test or soil pit in the alternate secondary area must be indicated.
23. Soil information in regards to redoximorphic features and bedrock found in the primary disposal site soil pit must be provided.
24. Pumped effluent systems
 - a. All pertinent data required for a conventional system must be provided. Indicate the calculated dose volume.
 - b. Provide the dose tank size (item 20b on EHP-19) and the construction details, including the inside dimensions. If a pump vault is used, indicate the proper, increased septic tank size in item 20a and on the plat drawing.
 - c. Provide details of the control panel, riser, and pump control assembly. Indicate whether the dose interval is controlled by timer or by demand. Specify what brand panel and control assembly are to be used.
 - d. Calculate the draw down in the dose tank and the show calculations used. Examples are: "On-off" points, elevations inside tank alarms, etc.
 - e. Provide the brand, model number and pump curve of effluent pump specified. Include the calculations used to determine the dose volume per minute and friction head.
 - f. Indicate the length and diameter of the pumped effluent line.
 - g. Indicate the length and diameter of the pipe from dose chamber to the distribution system.

- h. Indicate the elevation difference between the inlet to the distribution system and pump's shut-off elevation.
 - i. Provide details of the distribution system.
25. Indicate any diversion or distribution device to be used and its location.
26. Systems included in the Onsite Maintenance Program must be submitted with a valid contract with a Certified Maintenance Provider.

Designated Representative Site Responsibilities

1. All major system components shall be staked-out with all stakes identified. Examples include: the stub-out, tank, D-Box, the beginning middle and end of each lateral line. wells, etc.
2. The beginning, middle and end of all laterals shall be flagged in both the primary and alternate secondary site. **Exception:** The secondary site need not be flagged provided the lot is 1.5 acres or larger in size; the slope is less than 10 percent; or the secondary site is clearly acceptable.
3. All percolation test holes shall be flagged.
4. All soil pits shall be flagged.
5. The proposed system design must be appropriate for the site: flat ground, pumped effluent, serial distribution, dual absorption field, D-box, dosed, etc.
6. Note observations or other findings.

Appendix G

Lost Storage Formula

Variables:

Loading Rate (LR)	Most restrictive loading rate for primary site
Trench Loading Rate (TLR)	Loading Rate based on (depth to SWT - depth of backfill)
Width (W)	Width of absorption trench product
Desired Line Length (DLL)	Desired individual line length
Surface Loading Lines (SLL)	Number of lines that are capable of surface loading.
Length 1 (L1)	Total length of line/s that are capable of surface loading
Gallons Per Day (GPD)	Estimated gallons per day usage

Calculations:

Square feet of lines that are capable of surface loading:
 $W * L1 = Sqft1$

Gallons of storage in surface loading lines:
 $Sqft1 * LR = G1$

Remaining gallons to be stored:
 $GPD - G1 = G2$

Square feet required to store remaining gallons:
 $G2 / TLR = Sqft2$

Linear feet required to store remaining gallons:
 $Sqft2 / W = LF$

Number of lines needed to store remaining gallons:
 $LF / DLL = TLL$ (round up)

Total number of Lines:
 $TLL + SLL = \text{Total number of lines at desired line length (DLL)}$

Notes: Only the last line of the manifold and lines on the same (1 inch or less) elevation of the last line will be considered to surface load. Changes to desired line length will require complete recalculation.

Appendix H
Drawings

Fig. 1
Maximum Storage on Level Ground

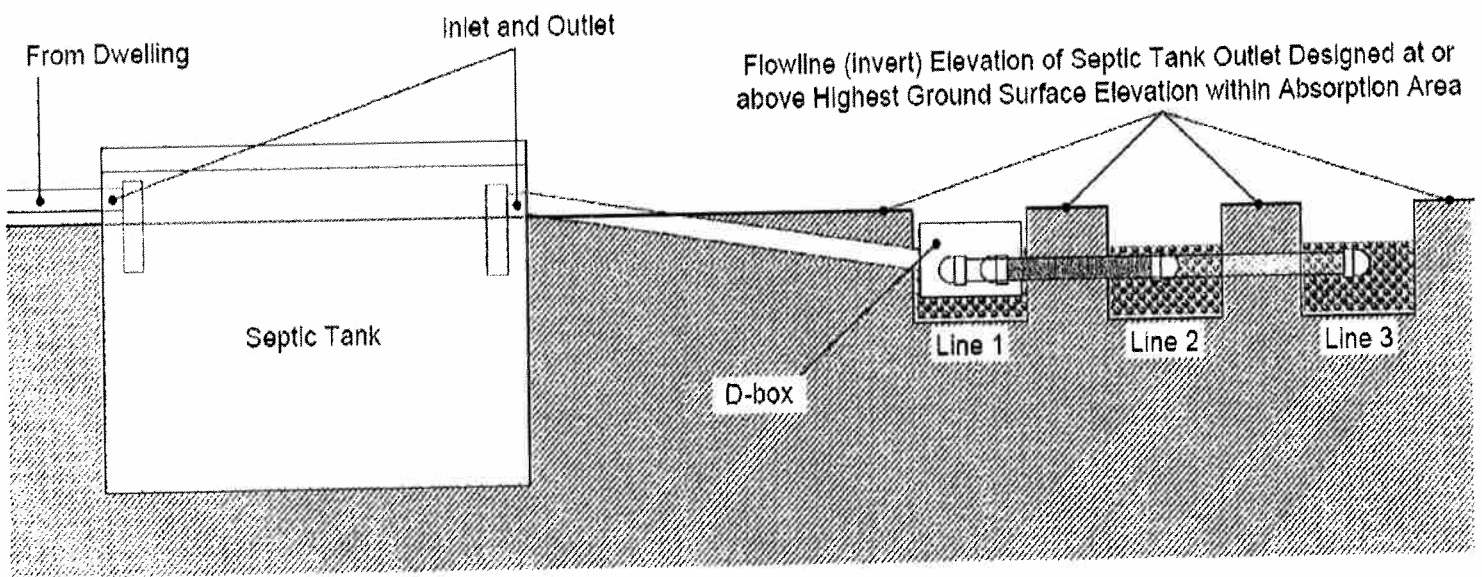

Fig. 2

Maximum Storage on Sloping Ground

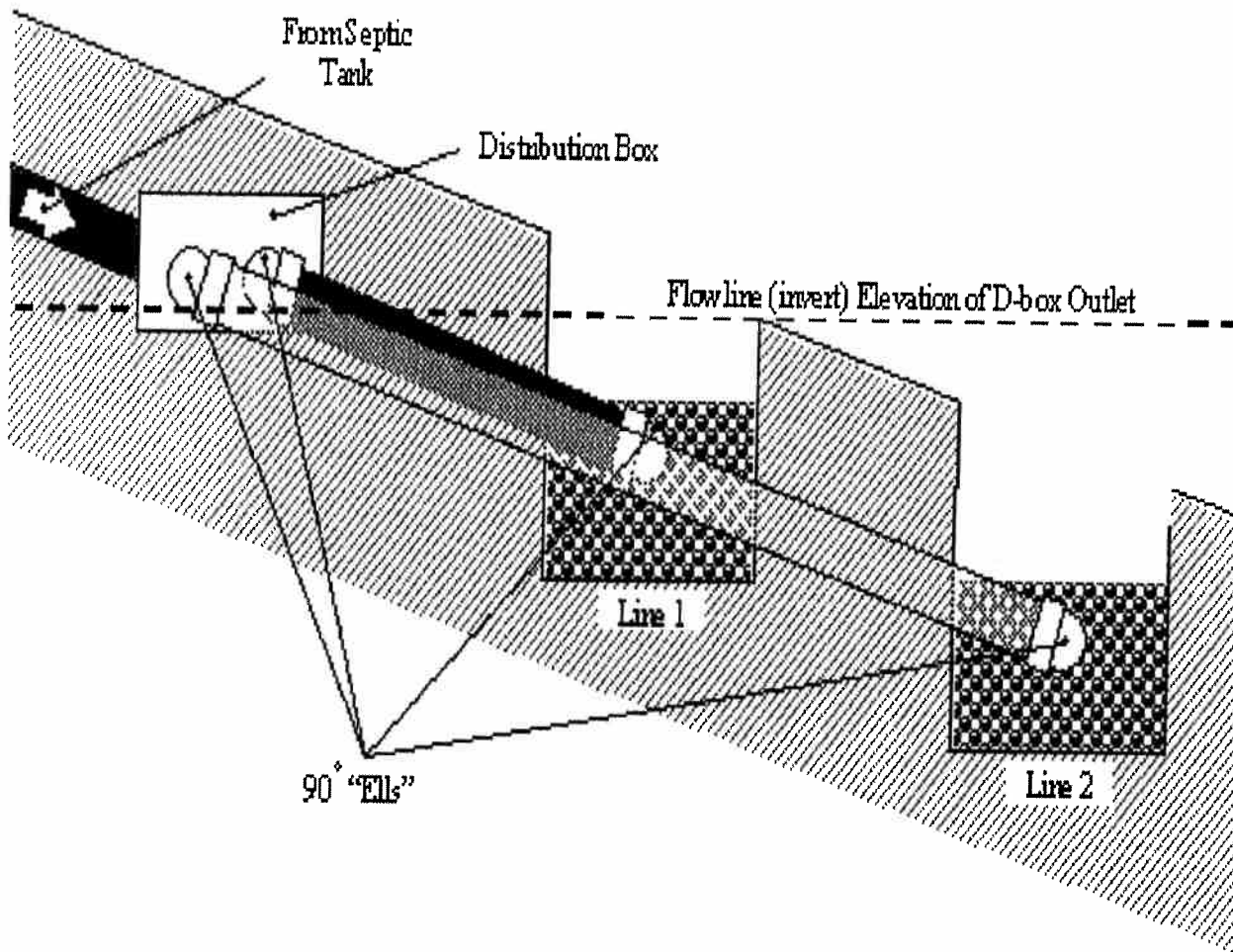

Fig. 3

Low Pressure Distribution Trench Detail

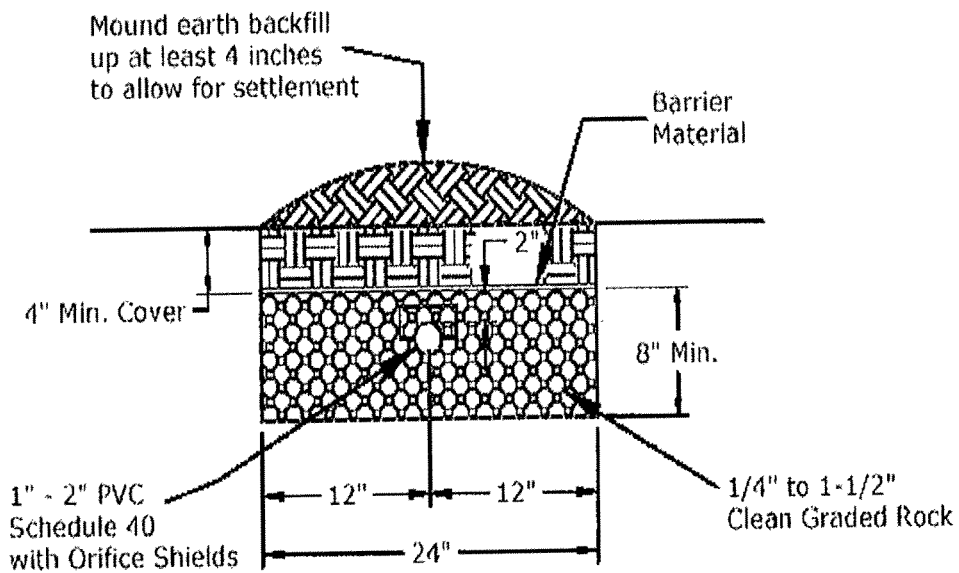

Fig. 4

Capping Fill System - Top View (Less Than 6% Slope)

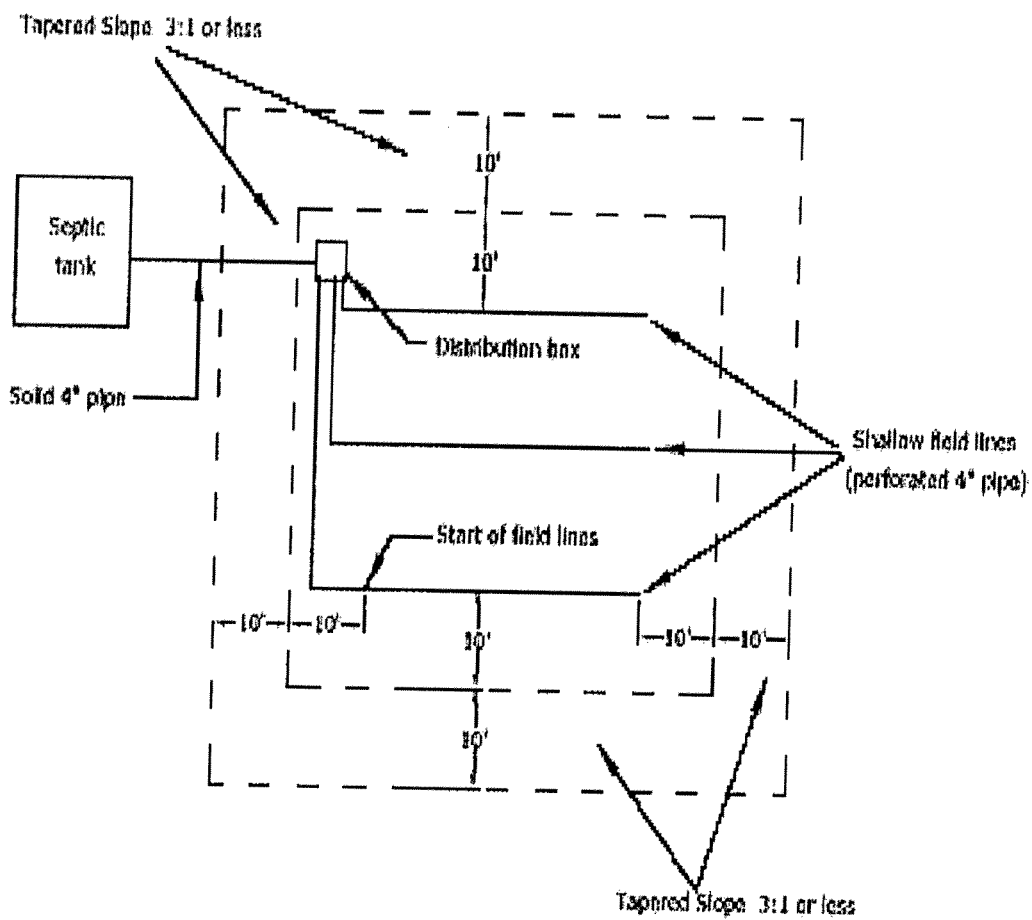
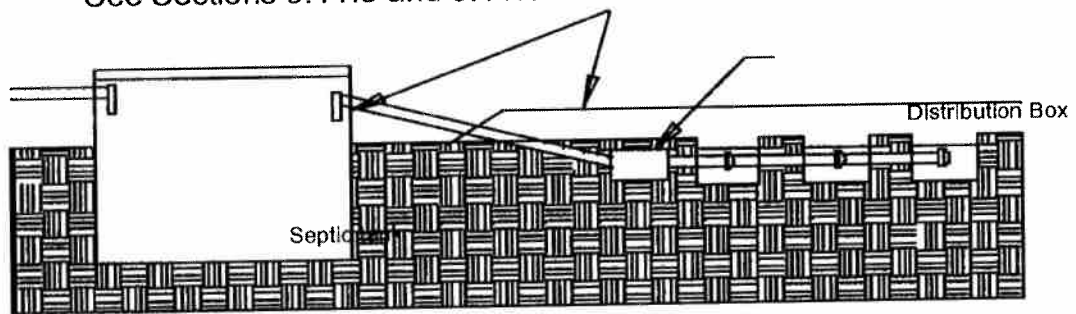

Fig. 5

Capping Fill System - Side View (Less than 6% Slope)

Location of the distribution box or septic tank outlet
determined by the fall across the absorption field.
See Sections 9.11.5 and 9.11.6



Note: Capping material must extend 10 ft. from trenches
before the start of the slope. The tapered slope shall be
3:1 or less.

Fig. 6

Capping Fill System - Top View (6% - 12% Slope)

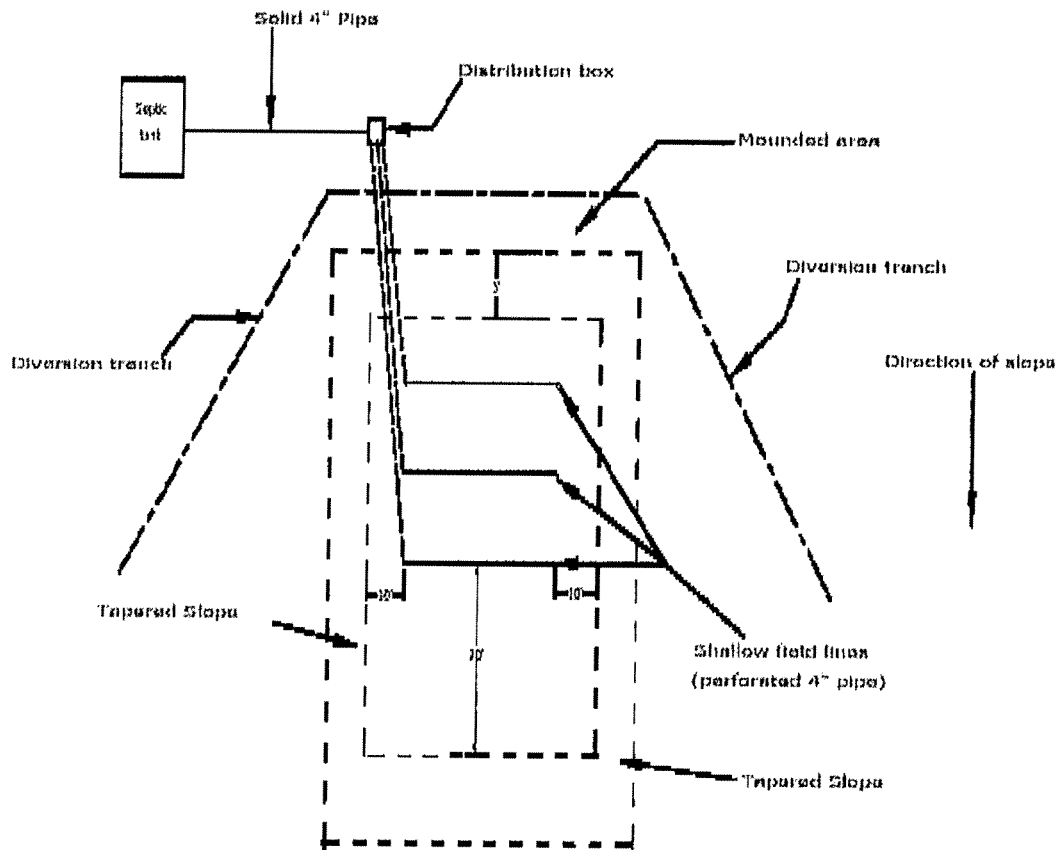

Fig. 7

Capping Fill System - Side View (6% - 12% Slope)

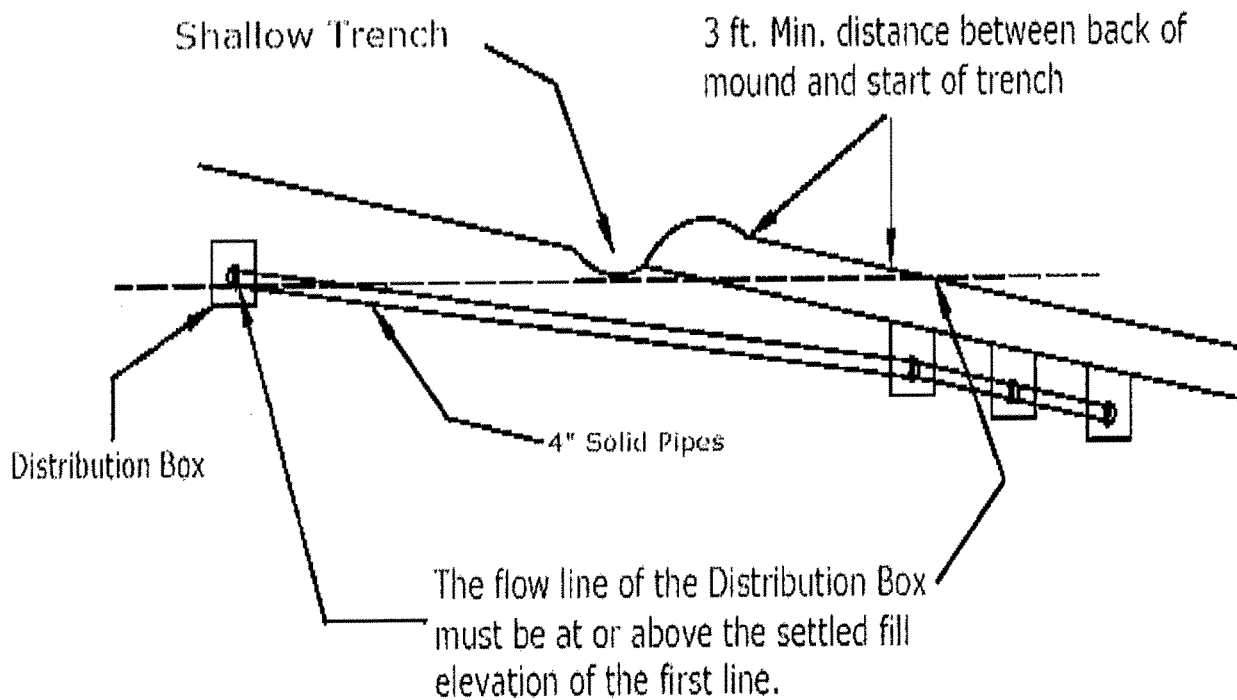

fig.8

Interceptor Drain (3% or greater slope)

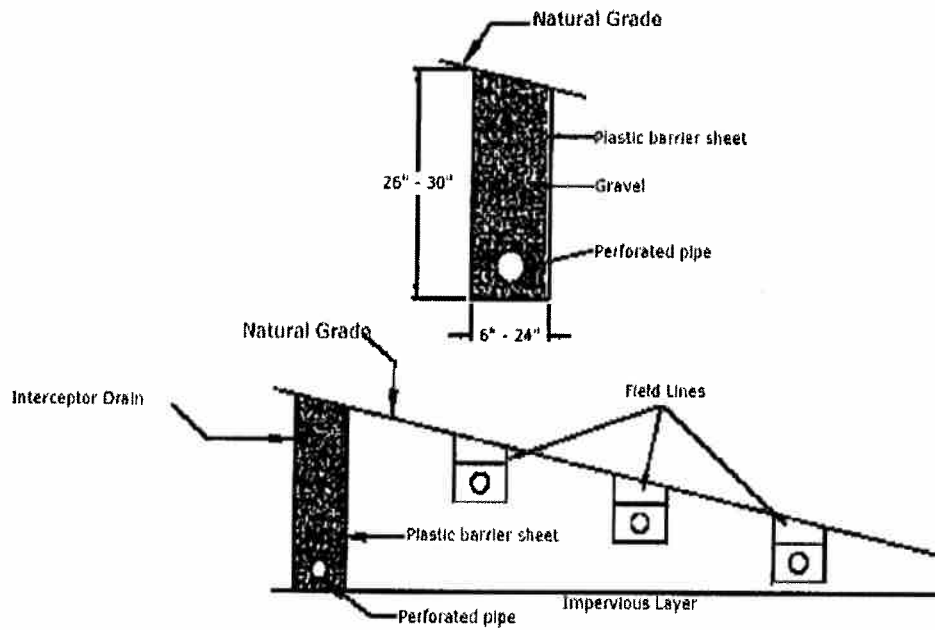

fig. 9

Lateral Line Trench Detail

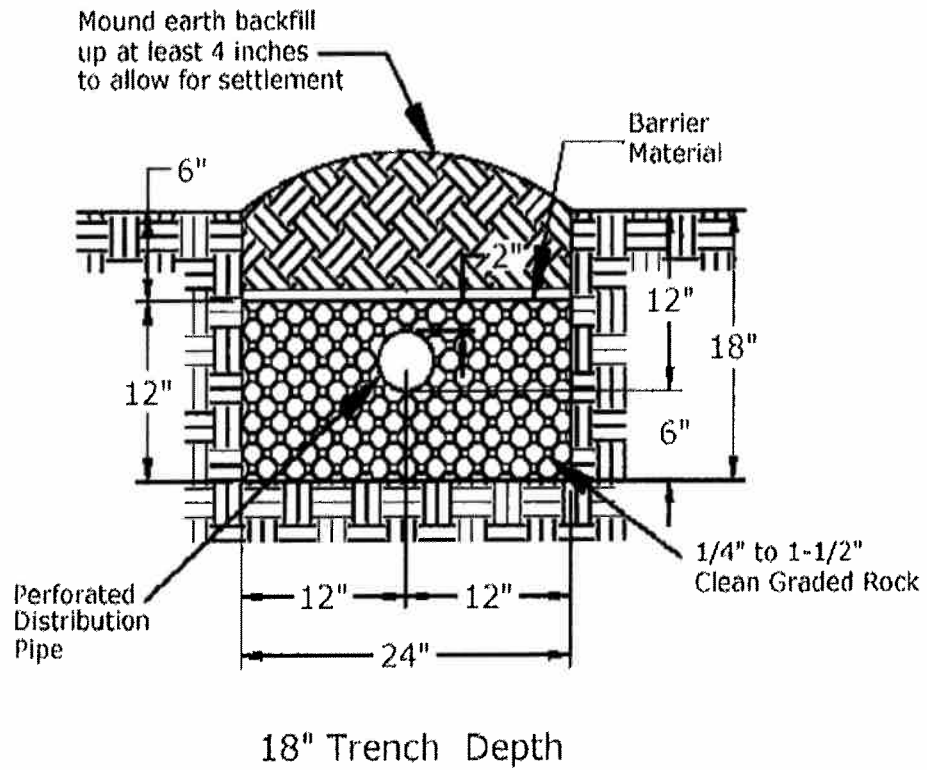

fig. 10

Short Manifold LPD

(Top Down Loading Configuration)

